

Raychem Screened Adaptor System RSES/RSSS 250 A, 24 kV

Raychem Screened Adaptor System RSES/RSSS 250 A, 24 kV



Raychem separable Screened Adaptors are designed to connect single-core polymeric cables to medium voltage equipment (transformers, switchgears, motors etc.) up to 24 kV.

Made of crosslinked EPDM and protected with a minimum 3 mm moulded conductive shield connected to earth, Raychem deadbreak adaptors are suitable for both indoor and outdoor installations.

Their wide application range allows a minimum number of bodies to cover several different cable cross-sections without the need for additional cable adaptors. The cut-back dimensions for all cable sizes are the same for our Raychem RSSS and Raychem RSES adaptors.

Raychem Screened Adaptors are equipped with a capacitive test point to ensure that the circuit is not energised before disconnection. The capacitive test point is protected by a conductive cap. A range of high strength bimetallic compression connectors tested to VDE 0220 are offered to connect both aluminium and copper conductor cables. After cable preparation and lubrication, the Raychem Screened Adaptors can simply be slid into place under virtually all conditions. A separable mounting system provides for an easy installation of the adaptor onto the bushing.



In addition, Rayvolve tubing or heat-shrink phase-marking sleeves are offered as an option, to provide a superior environmental seal.



Rayvolve Sealing

Cold applied technology. Rayvolve is used in conjunction with a pressure sensitive mastic and is simply rolled into place. Thus a reliable moisture seal is achieved. The use of Rayvolve is particularly recommended for applications where a torch is unavailable or cannot be used.



Heat-Shrinkable Sealing

Moisture seal and phase marking. A reliable moisture seal can also be produced by using a mastic in conjunction with a heat-shrinkable sleeve. This solution has the additional advantage of providing phase marking. A standard torch carried by most jointers is used.

Construction and Design

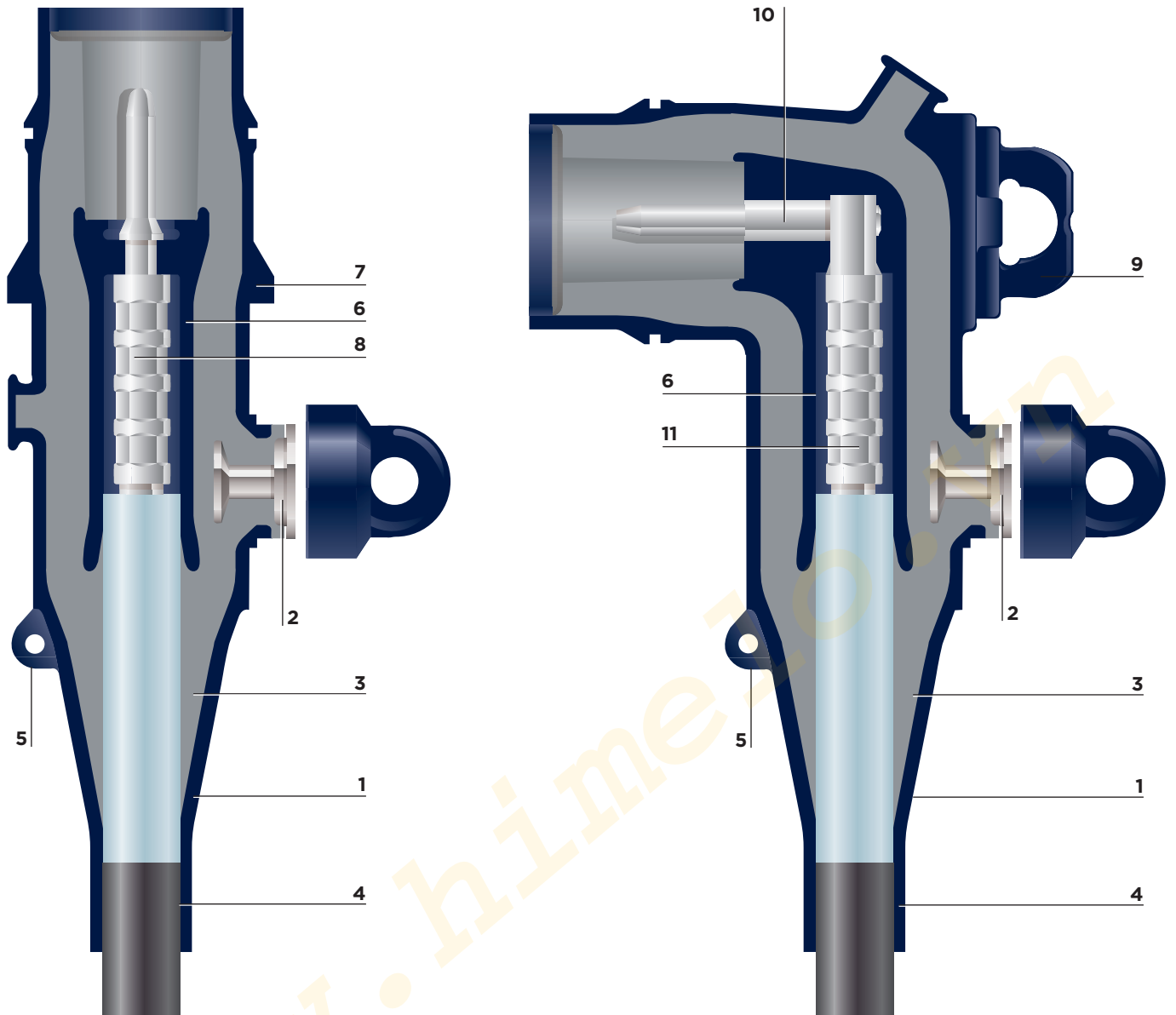

1 Screened Body

A 3 mm conductive moulded outer screen is permanently bonded to the EPDM insulating material of the body.

2 Capacitive Test Point

Used to determine if the circuit is energised; can also be used for phasing. Electrically protected by a cap made of EPDM.

3 Stress cone

Computer designed, it relieves electrical stress at the cable screen cut of the termination.

4 Conductive Cable Entrance

The 25 mm conductive end provides a connection to the cable screen.

5 Earthing Eye

Provides a connection point for the screen of the body to the earth.

6 Inner Screen

Conductive insert provides a “Faraday cage” around the compression connector and eliminates corona at rated voltage.

7 Retaining Shoulder

To fix a retaining collar onto the adaptor for easy installation with two screws.

8 Compression Pin-Connector

Bimetallic compression pin-connector designed with locking ring, to connect both aluminium and copper conductor cables.

9 Lifting Eye

A lifting eye firmly attached to a moulded-in insert provides a secure disconnection point.

10 Pin

Tin plated copper electrode, designed and tested to carry 250 A continuous current. The hexagonal wrench to fix the pin onto connector is supplied with each kit.

11 Compression Connector

Bimetallic compression connector to connect both aluminium and copper conductor cables.

Technical data	RSES	RSSS
Cable Insulation Diameter Range	13.5 - 33.5 mm	13.5 - 26.5 mm
Connector Cross section Range	16 - 120 mm ²	16 - 95 mm ²
Maximum System Voltage	24 kV	24 kV
Continuous Current Rating	250 A	250 A
Basic Impulse Level	125 kV	125 kV
Partial Discharge at 2 U ₀	< 5 pc	< 5 pc
AC Voltage Withstand, 1 min	50 kV	50 kV
DC Voltage Withstand, 30 min	96 kV	96 kV

The adaptors have been tested in accordance with the international specifications (e.g. ANSI/IEEE 386, IEC 540, VDE 0278). The bimetallic connectors have been tested in accordance with VDE 0220 on aluminium and copper conductors. All adaptors pass the routine tests including: AC Voltage Withstand, Partial Discharge Extinction and Test Point Voltage Test.

Selection Table

Screened Elbow Adaptors

Diameter over insulation	Cross section (Al or Cu conductor)						
	16 mm ²	25 mm ²	35 mm ²	50 mm ²	70 mm ²	95 mm ²	120 mm ²
13.5 - 17.4 mm	RSES 5201	RSES 5202	RSES 5203	RSES 5205	-	-	-
16.3 - 20.8 mm	RSES 5211	RSES 5212	RSES 5213	RSES 5215	RSES 5217	RSES 5219	-
19.6 - 24.1 mm	-	-	RSES 5223	RSES 5225	RSES 5227	RSES 5229	RSES 5224
23.1 - 27.7 mm	-	-	-	RSES 5235	RSES 5237	RSES 5239	RSES 5234
27.9 - 33.5 mm	-	-	-	-	-	RSES 5249	RSES 5244

Screened Straight Adaptors

Diameter over insulation	Cross section (Al or Cu conductor)					
	16 mm ²	25 mm ²	35 mm ²	50 mm ²	70 mm ²	95 mm ²
13.5 - 17.4 mm	RSSS 5201	RSSS 5202	RSSS 5203	RSSS 5205	-	-
16.3 - 20.8 mm	RSSS 5211	RSSS 5212	RSSS 5213	RSSS 5215	RSSS 5217	RSSS 5219
19.6 - 24.1 mm	-	-	RSSS 5223	RSSS 5225	RSSS 5227	RSSS 5229
21.0 - 26.5 mm	-	-	-	RSSS 5255	RSSS 5257	RSSS 5259

Add mod. code -R to kit number for cold applied tubing Rayvolve.

Add mod. code -P to kit number for heat shrink tubing with phase marking.

While TE Connectivity (TE) has made every reasonable effort to ensure the accuracy of the information in this catalog, TE does not guarantee that it is error-free, nor does TE make any other representation, warranty or guarantee that the information is accurate, correct, reliable or current. TE reserves the right to make any adjustments to the information contained herein at any time without notice. TE expressly disclaims all implied warranties regarding the information contained herein, including, but not limited to, any implied warranties of merchantability or fitness for a particular purpose. The dimensions in this catalog are for reference purposes only and are subject to change without notice. Specifications are subject to change without notice. Consult TE for the latest dimensions and design specifications. Raychem, TE Connectivity and TE Connectivity (logo) are trademarks. Other logos, product and company names mentioned herein may be trademarks of their respective owners.

TE Energy - innovative and economical solutions for the electrical power industry: cable accessories, connectors & fittings, insulators & insulation, surge arresters, switching equipment, street lighting, power measurement and control.

Tyco Electronics Raychem GmbH
a TE Connectivity Ltd. Company
TE Energy
Finsinger Feld 1
85521 Ottobrunn/Munich, Germany

Phone: +49-89-6089-0
Fax: +49-89-6096345

energy.te.com